

ZEISS DTC

3/38 | 3/25

Instructions for use

For United States patents which may cover this product see our website.
Patents: www.zeiss.com/cop/patents

DE **EN** FR ES IT NL DK FI HU PL SE RU JP CN | 01.2022



**WARNING!**

Please note the safety instructions and regulatory information. They can also be accessed at:
www.zeiss.com/hunting/manuals

**Installing/removing the battery**

The ZEISS thermal imaging attachment is equipped with a battery. It cannot be removed.

Attaching the thermal imaging attachment

An adapter is required to attach it to an optical device, e.g. a rifle scope. To expose the thread for attaching the adapter, turn the lock ring **(6)** as far clockwise as possible in the direction of the thermal imaging attachment. Hand-tighten your external adapter clockwise onto the device. Secure the connection by turning the lock ring **(6)** counterclockwise in the direction of the external adapter. Please also observe the mounting instructions enclosed with your adapter.

Note: Check the legal and regional regulations in your country before using the ZEISS DTC 3 in combination with an optical sight.

INSTRUCTIONS FOR USE

ZEISS products are famous for outstanding optical performance, precision workmanship, and long service life.

Please observe the following instructions for use to obtain the best results from your thermal imaging attachment and to ensure it remains as your preferred gear for many years to come.

Scope of supply

	Product	Order no.	Scope of supply
ZEISS DTC	3/38	527031	DTC 3/38 or DTC 3/25 thermal imaging attachment Protective lens cap Eyepiece protection Carrying case Optics cleaning cloth
ZEISS DTC	3/25	527030	USB cable Quick Guide Safety instructions Warranty card EULA document

TECHNICAL DATA

		DTC 3/38	DTC 3/25
Optics			
Focal length		38 mm / F1.0	25 mm / F1.0
Lens type		Germanium	
Range	m (object 1.8 m × 0.6 m) yd (object 2 yd × 0.7 yd)	1,950 (2,130)	1,300 (1,420)
Field of view in m at 100 m (Field of view in m at 100 yd)	m (ft)	12.3 (36.9)	18.4 (55.2)
Field of view in degrees (horizontal × vertical)	°	7 × 5	10.5 × 7.9
Optical magnification		1	
Maximum image adjustment X to 100 m (Maximum image adjustment X to 100 yd)	cm (ft)	± 205 (6.7)	± 307 (10.1)
Maximum image adjustment Y to 100 m (Maximum image adjustment Y to 100 yd)	cm (ft)	± 154 (5.1)	± 230 (7.5)
Adjustment per click at 100 m (Adjustment per click at 100 yd)	cm (in)	1.6 (0.58)	2.4 (0.86)
Sensor			
Sensor resolution	px	384 × 288	
Sensor pixel pitch	µm	12	
Frame rate	Hz	50	
Display			
Display resolution	px	1,024 × 768	
Display type		AMOLED	
Electronics			
Interfaces		USB: charging Bluetooth: data transfer	
Battery		Lithium-ion	
Battery life	h	10	
External power supply (not included in the delivery package)		5V / 2A (USB)	
Connection with other devices		ZEISS Hunting App, Bluetooth	
General			
Protection type		IP65 / IP67 (protected from heavy rain)	
Operating temperature range	°C (°F)	-10 / +50 (+14 / +122)	
Length × width × height	mm (in)	164 × 60 × 65 (6.5 × 2.4 × 2.6)	150 × 60 × 65 (5.9 × 2.4 × 2.6)
Weight	g (oz)	650 (22.9)	560 (19.8)

Subject to changes in design and scope of delivery and as a result of ongoing technical development.

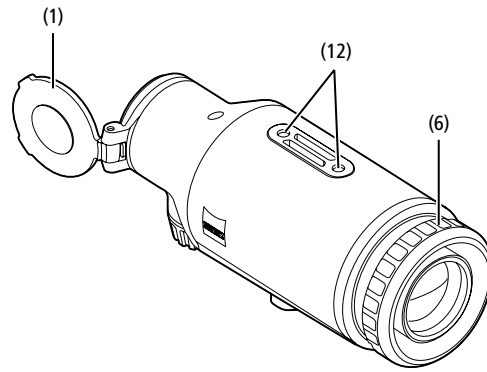
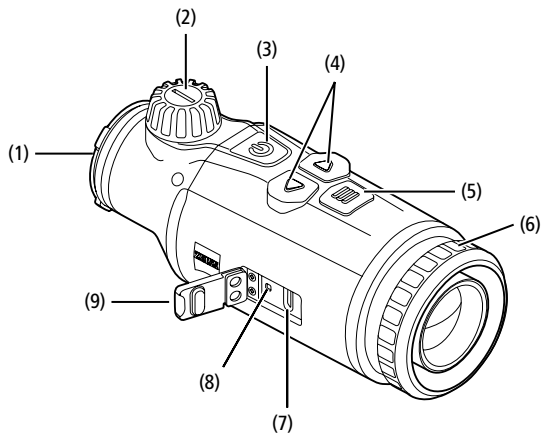

Power on/off

Press and hold the on/off button **(3)** (approx. 1.5 seconds) to switch on the device. Press and hold the on/off button **(3)** to switch off the device again.

Note: The on/off button **(3)** must be pressed until the OFF symbol appears on the display. Only then can the on/off button **(3)** be released and the device switches off. If the on/off button **(3)** is released before the OFF symbol is displayed, the device does not switch off but switches to standby mode.

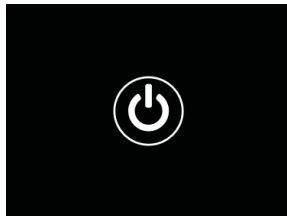

Standby mode

Briefly press the on/off button **(3)** to switch the device to standby mode. Briefly press the on/off button **(3)** again to switch the device back to observation mode.

To further conserve battery power and extend running time, the ZEISS DTC 3 offers Smart Standby with a built-in motion sensor. This automatically detects the position of the thermal imaging attachment and activates standby mode at 45° lateral inclination or 70° downward or upward inclination. As soon as the thermal imaging attachment returns to its normal position, the device automatically switches back to observation mode. You can deactivate this function in the menu under "Smart Standby".

Calibration

The device can be calibrated automatically (Auto Calibration = On) or manually (Auto Calibration = Off). This can be set in the main menu or via the right arrow button **(4)** in observation mode.

In automatic mode, the device automatically performs a calibration by closing and opening an internal shutter when necessary. A gentle click should be heard. In this mode, you also have the option of performing the calibration manually. Briefly press the right arrow button **(4)**. The device activates the shutter and calibrates itself. The device is now calibrated again.

To perform a manual, silent calibration, first switch to observation mode by pressing and holding the right arrow button **(4)** in manual mode. To calibrate, cover the lens and then briefly press the right arrow button **(4)**.

Note: Always cover the lens when performing a manual calibration. Otherwise the sensor cannot calibrate correctly and the image will deteriorate, e.g. ghost images. If you forget to cover the lens during a manual calibration, repeat the calibration procedure with the lens covered.

Observation mode

Turn the focusing turret **(2)** to bring the scene into focus.

Color modes

The scene can be displayed in four different color modes. Briefly press the menu button **(5)** to change the observation mode. When changed, the selected mode is shown on the display as text for about 2 seconds. The following color modes can be selected:

- **White Hot:** Cold areas are displayed here in black and warm areas in white.
- **Black Hot:** Cold areas are displayed here in white and warm areas in black.
- **Red Hot:** Cold areas are displayed here in black and warm areas in white. In addition, the warmest areas are shown in yellow to red.
- **Rainbow:** A varied color palette displays cold areas in black to blue and warm areas in yellow to white.

Menu

Press and hold the menu button **(5)** to show the main menu on the display. The main menu gives you the following options:

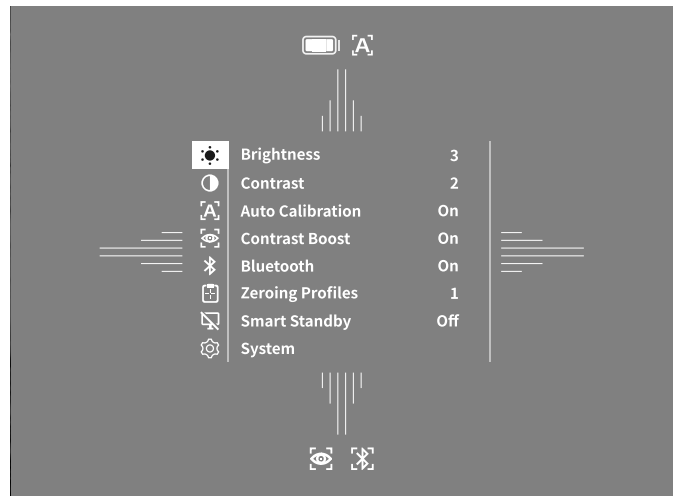

- **Brightness:** Set the brightness of the display here. There are four brightness levels to choose from. The brightness is lowest at level 1. The brightness is highest at level 4.
- **Contrast:** Adjust the contrast of the scene here. There are four contrast levels to choose from. The contrast is lowest at level 1. The contrast is highest at level 4.
- **Auto Calibration:** Set manual (Auto Calibration = Off) or automatic calibration (Auto Calibration = On) here.
- **Contrast Boost:** Activate this mode for better visibility in high humidity or fog.
- **Bluetooth:** Enable Bluetooth (Bluetooth = On) or disable (Bluetooth = Off) Bluetooth. With Bluetooth turned on, the device can be connected to your smartphone and the app.
- **Zeroing Profiles 1–4:** Select the zeroing profile you created for the riflescope you are currently using.
- **Smart Standby:** Activate (Smart Standby = On) or deactivate (Smart Standby = Off) the automatic standby mode.
- **System:** Make all system-relevant settings here, including zeroing, language, time and factory reset.

The arrow buttons (4) and the menu button (5) are used to navigate in the main menu. Press the right arrow button (4) to scroll down. Press the left arrow button (4) to scroll up. Briefly press the menu button (5) to select a menu item. This opens the submenu. Make your settings using the arrow buttons (4). Briefly press the menu button (5) to confirm your selection and return to the main menu. Press and hold the menu button (5) to exit the main menu and return to observation mode.

Contrast Boost

The contrast boost enables you to display the image in an improved way in high humidity or fog. This highlights edges so that structures can be recognized better. To activate the contrast boost on your device, select "Contrast Boost" in the main menu. Then select "On" or "Off". Briefly press the menu button (5) to confirm the selection.

Note: It is recommended to use this mode only in the above-mentioned conditions and to disable this mode in normal conditions.

Zeroing Profile 1-4

Up to four different zeroing profiles can be stored on your device. To change the profile, select "Zeroing Profile 1-4" in the main menu. Select the desired profile and confirm the selection by briefly pressing the menu button (5).

System

The "System" submenu has the following options:

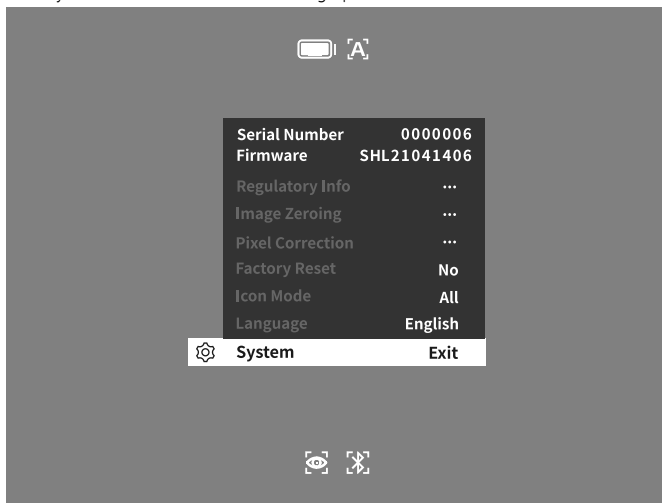

- **Regulatory Info:** Here you can find information about the licenses used and regulatory information.
- **Image Zeroing:** Adjust the thermal imaging attachment to perfectly fit your riflescope here.
- **Pixel Correction:** Remove defective pixels for a perfect field of view.
- **Factory Reset:** Select "Factory Reset" to reset the device to the factory settings. This also deletes all settings saved on the device.
 - Note:** If you perform a factory reset, all zeroing profiles will be deleted. Only perform a factory reset if you want to delete all settings on the ZEISS DTC 3.
- **Icon Mode:** Select the number of icons to be shown on your display.
- **Language:** Select a menu language here.

You can also view the following information:

- **Serial Number:** The serial number of your device is shown here.
- **Firmware:** The current firmware version is displayed here.

Image Zeroing

Select "System" in the main menu to set the selected zeroing profile. Navigate to "Image Zeroing" and start the zeroing procedure by briefly pressing the menu button (5). Setting the X axis: Press the left arrow button (4) for minus and the right arrow button (4) for plus. Each time you press the button, the image shifts in the corresponding direction: at 25 mm focal length by 2.4 cm at 100 m, at 38 mm focal length by 1.6 cm at 100 m. Confirm the setting by briefly pressing the menu knob (5). Now make the settings for the Y axis in the same way. Switch between the setting for the X and Y axis by briefly pressing the menu button (5).

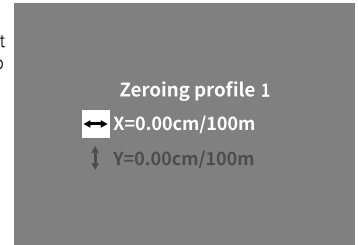

To correct the impact point, move the image opposite to the direction to which you detected the deviation, i.e.:

- Shot placement too far to the left: Correction to the right
- Shot placement too far to the right: Correction to the left
- Shot placement too far to the bottom: Correction to the top
- Shot placement too far to the top: Correction to the bottom

To save the settings, press and hold the menu button (5). Confirm the query whether you want to save or discard the calibration by briefly pressing the menu button (5).

To change an already saved zeroing profile, select "System" in the main menu. Then navigate to "Image Zeroing". Briefly press the menu button (5) to restart the zeroing procedure. Proceed as described above.

To save the settings, press and hold the menu button (5). Confirm the query whether you want to save or discard the calibration by briefly pressing the menu button (5).

Note: The currently selected profile will always be changed.

Simplified Zeroing Mode

The ZEISS Hunting App offers you a zeroing assistant for zeroing in. Navigate to the "Zeroing Profiles" menu item in the app and enter the deviations in relation to the distance of the respective axis. The device then performs the calibration automatically. For more information, please contact ZEISS Hunting App.

Pixel Correction

If individual pixels fail, you can locate them here and fix the error.

Select "System" in the main menu to start the correction. Navigate to "Pixel Correction" and start the correction by briefly pressing the menu button (5). A crosshairs appear, which you use to capture the affected pixel. For more precise detection, the area around the crosshairs is displayed enlarged in an additional window.

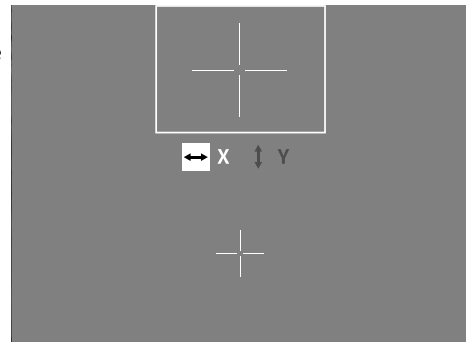

Setting the X axis: Press the left arrow button (4) for minus and the right arrow button (4) for plus. Every time you press the button, you move one pixel further. To jump several pixels further, hold down the arrow button (4) longer. Confirm the setting by briefly pressing the menu button (5). Now make the settings for the Y axis in the same way. Switch between the setting for the X and Y axis by briefly pressing the menu button (5).

To save the settings, press and hold the menu button (5). Confirm the query whether you want to save or discard the calibration by briefly pressing the menu button (5).

Factory Reset

To perform a factory reset, select "System" in the main menu. Then navigate to "Factory Reset". Select "Yes" and confirm your selection. A second security prompt follows, which must also be confirmed with "Yes".

Note: If you perform a factory reset, all zeroing profiles will be deleted. Only perform a factory reset if you want to delete all settings on the ZEISS DTC 3.

Note: The device must be restarted for the reset of the settings to be completed successfully.

Icon Mode

With the ZEISS DTC 3, you have the option of having various icons shown on the display: battery icon, calibration mode, Bluetooth, contrast boost. To set the icon mode, select "Icon Mode" in the System menu. Then choose between the following modes and confirm your selection by briefly pressing the menu button (5):

- **Non:** No icons are displayed.
- **Bat:** Only the battery symbol with the current charge status is displayed.
- **All:** All icons are displayed.

Personal data when you dispose of or pass on your ZEISS device

Before passing on the device to a third party, please perform the factory reset to delete data and verify it has been deleted. By doing so, you help maintain your privacy and data security.

Cooperation on device safety

Please take an active role in protecting the IT security of your device by using the ZEISS Hunting App and installing new firmware updates as soon as they become available.

Firmware update

A firmware update can be carried out using the ZEISS Hunting App. Follow the instructions for this in the ZEISS Hunting App.

Note: If you initiate an update via the ZEISS Hunting App, you must confirm this again on the device for security reasons.

Note: Make sure that the device is fully charged before updating the firmware. Do not switch off the device during the update, otherwise it may be damaged.

LED status

Note: The LED is located under the cover for the USB charging socket.

Charge state	LED color	LED status
Does not charge	-	-
Does not charge (low charge level)	Red	Flashing
Charging	Red	Constant
Charging (fully charged)	Green	Constant

ZEISS Hunting App

Install the ZEISS Hunting App on your smartphone and open the app. To connect to the thermal imaging attachment, activate Bluetooth on your thermal imaging attachment and follow the steps displayed in the app. The app enables you to make settings, use the ZEISS DTC 3 via remote control mode and use the simplified zeroing mode. A more detailed description can be found in the help function of the app.

Charging the device

Charge the device via the USB port (7) when the battery is empty. To do this, first open the rubber cover on the side of the device (9).

The battery charge level is shown in the upper left corner of the display. When the charge level is low, the display changes to red. When the device is being charged, the LED (8) lights up red when the device is switched on and off. When the battery is fully charged, the LED (8) lights up green.

Replacing the lens cap

To replace the protective lens cover (1), loosen the front part of the lens cover by turning it counterclockwise. Unscrew the lens cover completely. Then screw the new lens cover back on.

Replacing the USB cover

To replace the USB cover (9), unscrew the screws (13) using a screwdriver. Remove the retaining plate (14) and the defective USB cover (9). Insert the new USB cover (9) and the retaining plate (14). Tighten the screws (13) using a screwdriver.

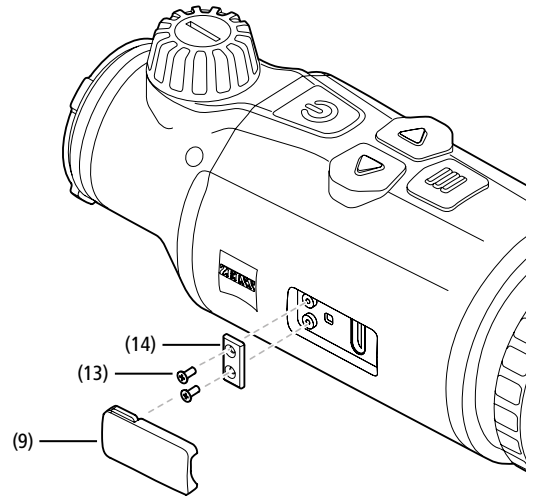

Adapter

Two ¼-inch standard threads (12) are located on the bottom of the device. These offer you the option of attaching an adapter here, e.g. for a Picatinny rail.

Care and maintenance of the device

Do not wipe off coarse dirt particles (e.g. sand) from the lenses, rather blow them away, or use a fine brush to remove them! Over time, fingerprints can corrode the lens surface. Breathing on the lens and polishing it with a clean optical cleansing cloth is the easiest method of cleaning the lens surface. Dry storage and keeping the outer lens surfaces well ventilated, especially in the tropics, helps to prevent a possible mould film forming on the optics. Your thermal imaging attachment requires no further special care.

Software updates

Within the scope of the statutory warranty (2 years from the transfer of risk of the goods - according to German law), we will provide appropriate updates to remedy defects. Generally, updates are used for security-related aspects or to eliminate functional impairments and do not include new functions of the software. Insofar as the provision of new functions is necessary to remedy security aspects, this shall not in principle constitute a claim to new functions as such.

After the legal warranty period has expired, we will of course endeavor to provide you with appropriate further updates. However, there is no entitlement to this.

Troubleshooting

Fault	Possible reasons	Solution
Will not boot.	Battery is empty.	Charge the device.
	External power supply is not sufficient.	Check if the external power supply is fine.
The device is not charging.	The USB cable is not properly connected to the device.	Unplug the USB cable and check that the connector and port are undamaged and free from dirt.
The image is unclear. The image has streaks. The background is not uniform.	The device must be recalibrated.	Follow the instructions when performing the calibration procedure.
The image is blurred.	The contrast boost is activated despite normal conditions.	Deactivate the contrast boost.
The image is too dark.	The screen brightness is set too low.	Adjust the screen brightness.
The image on the display is flat.	The contrast is set too low.	Adjust the contrast.
Image quality is poor. The detection range is too short.	Poor weather conditions may have adverse effects (e.g. heavy snowfall, rain, fog, etc.).	

Care and maintenance of the battery

Follow these steps to extend the battery life:

- Only store the device at temperatures ranging between 0 and 35°C.
- Avoid storing the device with a fully charged battery.
- Avoid complete discharging of the device.

Customer Service and Warranty



For service questions or obtaining the warranty terms, please see our website:

www.zeiss.com/cop/warranty

For service inquiry or a free copy of the warranty terms for your region, please contact:

ZEISS Customer Service

Zeiss Sports Optics GmbH
Gloelstr. 3-5, 35576 Wetzlar, Germany
Phone: +49 800 934 77 33
E-mail: consumerproducts@zeiss.com

ZEISS Customer Service USA

Carl Zeiss SBE, LLC
Consumer Products
1050 Worldwide Blvd.
Hebron, KY 41048-8632, USA
Phone: +1-800-441-3005
E-mail: info.sportsoptics.us@zeiss.com

Manufacturer's address

Carl Zeiss AG
Carl-Zeiss-Straße 22
D-73447 Oberkochen
www.zeiss.com/nature und www.zeiss.com/hunting

Subject to changes in design and scope of delivery and as a result of ongoing technical development. No liability for mistakes and printing errors.

Data protection notice

Personal data is processed when using the thermal imaging attachment. Our information on data protection and the processing of personal data can be found in our download center: www.zeiss.com/hunting/manuals